

## Panel Sizing for Solar PV Panel Area Requirement and Performance at Various Locations

Mayank Pant\* and Lalit Kumar Sharma\*\*

---

### ABSTRACT

*The solar photovoltaic (PV) technology used today is one of the most widely used renewable energy generation technologies. This essay compares the PV panel efficiency for some of the same environmental factors at three different Indian locations, Mathura, Ladakh, and Bikaner, at the same time and location. The PV panel has a boost converter integrated in to provide the necessary voltage at the load side. The PV Panel Simulation model is tested while variations in current, voltage, and power at the surface of the panel and at the load are tracked by simulating it with PSIM for different irradiance and temperature. After these figures are obtained, the efficiency of the current panel will change on the basis of the impact of elevated cell temperature and irradiance, as well as the earlier determined panel functioning parameter values. The numerical values of the performance parameters will also dictate the physical dimensions of the PV panel and the area needed for it to generate 1kW of power.*

**Keywords:** Photovoltaic, efficiency, fill factor, short circuit, open circuit..

---

### 1.0 Introduction

Daily technological advancements increase our need for power to operate the machinery that enables those advancements. But today, both conventional and unconventional methods of electricity generation are used to meet our energy needs [1]. However, as we are all aware, conventional techniques rely on resources that are not self-renewing, which means they cannot be replenished naturally or on their own. However, for them to renew themselves, it would take millions of years. Natural resources include fossil fuels like coal, oil, diesel, and natural gas [2]. The power companies use these fossil fuels to generate electricity, but they are high in carbon compounds that harm the environment. These traditional methods of generating electricity caused changes in the global climate. Both people and all other living things—on land or in the sea—suffer greatly from the pollution that is caused by emissions from generating stations. The majority of the electricity in the world is produced by thermal power plants. The thermal power plant uses a variety of fuels, such as coal, diesel, and gasoline, to heat a sizable boiler with a lot of water. Water in the boiler heats up to the point where it turns from liquid to steam, which is very hot, and flows through pipes to the turbine section, where it rotates the turbine and uses a generator to produce electricity. Fossil fuels, on the other hand, have an adverse effect on the environment and are not naturally renewable.

---

\*Senior Advisor HR, Dysmech Competency Services, Pune, Maharashtra, India  
(E-mail: Mayankpant@dcsplm.com)

\*\*Corresponding author; Senior Advisor HR, Dysmech Competency Services, Pune, Maharashtra, India  
(E-mail: Lalit.kumar@dcsplm.com)

We must effectively use them or save them in order to maximize output. Due to the abundance and affordability of these sources in nature, scientists are turning to unconventional energy sources to address the issue of the scarcity of fossil fuels [3].

Consider the energy derived from sources like the sun, wind, geothermal, tidal, and wave. However, as a novel source of energy, solar energy will be the main focus of this section. We are all aware that the sun's heat is unrestricted and present for roughly 360 days out of the year. Wherever you are on Earth, though, determines how intense it is. Scientists created a system that can convert solar heat energy into electrical energy in order to use solar energy. The photovoltaic effect is the mechanism that makes it possible to convert heat energy into electrical energy. We need a unique device, though, to carry out this conversion [4]. The device that utilizes this feature is the photovoltaic cell. The cell draws energy from the sun to run its processes. Light exists as photons, each of which has a specific amount of energy, as we are all aware.

The electron receives this energy and is then excited, moving from the valence band to the conduction band. The circuit's electric current is produced by the movement of the circuit's electrons. Direct current is the only one that a solar cell can produce. A solar cell will therefore always produce a direct current, but because a single cell's voltage output is quite low by nature, we need high voltage to run our machinery. To achieve higher voltages, we must arrange numerous solar cells of this type in particular patterns. When the cells are arranged in a particular way to produce high voltage, a PV panel or PV array is produced [5].

Consequently, the total power generated by all of the photovoltaic cells in the panel when it harnesses solar energy is the same as the total power generated by all of those cells. The performance of a solar cell is, however, influenced by a number of characteristics and factors. These are short circuit current, open circuit voltage, fill factor, and efficiency. The equations below demonstrate how various performance parameters are interdependent on one another.

- a) Fill Factor =  $\frac{V_{pm} * I_{pm}}{V_{oc} * I_{sc}}$  ...1
- b) Efficiency ( $\eta$ ) =  $\frac{P_m}{P_{rad}}$  ...2
- =  $\frac{V_{pm} * I_{pm}}{P_{rad}}$  ...3
- =  $\frac{P_{rad}}{V_{oc} * I_{sc} * F.F}$  ...4
- c)  $I_{sc} = q * A * G (L_n + L_p + W)$  ...5
- d)  $V_{oc} = \frac{KT \ln \left\{ \frac{I_L}{I_0} + 1 \right\}}{q}$  ...6

**Figure 1: Equivalent Diagram of a PV Cell**

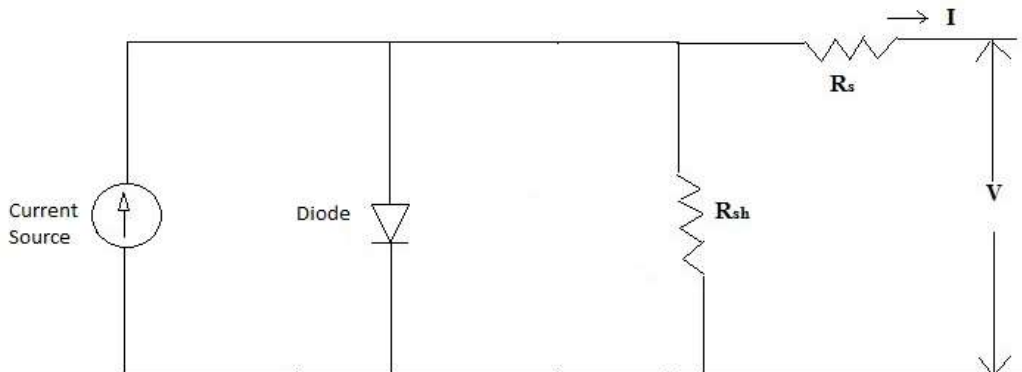

An analogous diagram of a solar cell with two different types of resistance—shunt resistance and series resistance—both of which are supplied by an ideal current source is shown in Figure 1 in the text below [6]. Series resistance should be as low as practical, in contrast to shunt resistance, which should be as high as possible.

### 2.0 Design Considerations of Boost Converter

A boost converter is a device that boosts or raises voltages. In this device, the voltage acquired at the output side is higher than the voltage acquired at the input side [7]. Even so, a small amount of power is lost as a result of the converter's internal voltages being raised. But this device does not include the DC to AC conversion and the subsequent AC to DC conversion because it would be a time-consuming and inefficient process. This type of converter is referred to as a switch mode dc-dc converter because it contains a MOSFET switch, a semiconductor component with the ability to switch on and off quickly [8] a source of periodic square waves, an inductor, a diode, and a capacitor are also present.

Due to the fact that, when compared to the input side, approximately 99 percent of the energy is acquired on the output side and only 1 percent is lost during the conversion process, such converters have a very high efficiency [9]. The inductor, which is also feeding the source and load, has reverse polarity, which is what caused this to happen. Below is a diagram of the fundamental boost converter model, which consists of an inductor, a diode, a capacitor, a MOSFET switch, and a resistive load.

**Figure 2: DC-DC Converter**

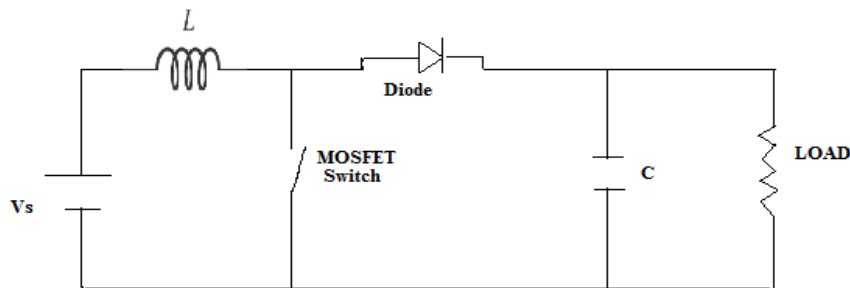

**Table 1: Characteristics of dc-dc Converter**

Sr. No.	Variable	Parameter	Value
1	Cells used	Duty cycle	0.6
2	$P_{max}$	Frequency	25KHz
3	$V_{Pmax}$	Resistance	60 $\Omega$
4	$I_{Pmax}$	$\frac{\Delta V_o}{V_o}$	0.002
5	$V_{OC}$	$C_{min}$	0.0001 F
6	$I_{SC}$	$L_{min}$	0.0026 H
7	Temperature Coeff. Of $V_{oc}$	$C_{used}$	0.004 F
8	Temperature Coeff. Of $I_{sc}$	$L_{used}$	0.4 H

$$L_{min} = \frac{D(1-D^2)R}{2f} \quad \dots 7$$

$$C_{min} = \frac{D}{R\left\{\frac{\Delta V_o}{V_o}\right\}f} \quad \dots 8$$

### 3.0 PSIM Simulation Model

The average global warming rate from 1951 to 2012 was 0.11 degrees Celsius [10] per decade, according to the IPCC's 2013[11] report. The report also points out that the trend for the preceding 15 years [12], from 1998 to 2012, was only 0.04 degrees Celsius per year [13]; the IPCC referred to this decrease in global warming as a pause [14].

**Figure 3: Simulation Model of PV Panel Integrated with a Boost Converter with a Resistive Load**

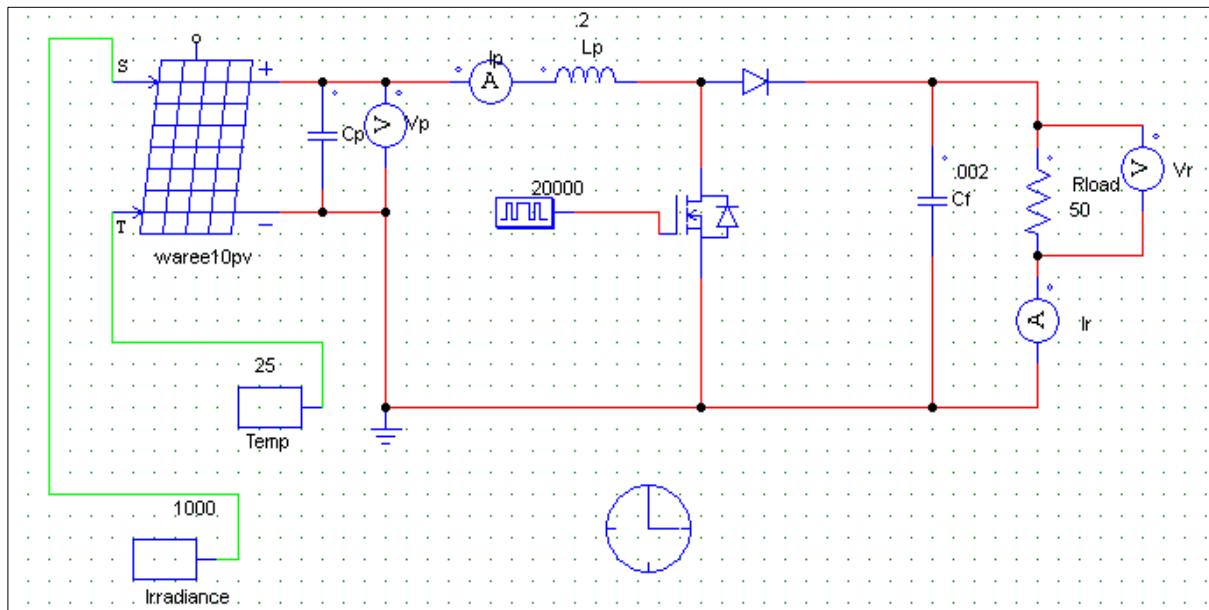

**Table 2: Specifications of PV Panel**

Sr. No.	Factors	Value
1	Number of solar pv units	38
2	Maximum power	65 W
3	$V_{Pmax}$	17.6 V
4	$I_{Pmax}$	3.8 A
5	$V_{OC}$	22.1 V
6	$I_{SC}$	4.2 A
7	Temp. Coefficient for open circuit voltage	-0.42 % / °C
8	Temp. Coefficient for open circuit current	0.0751% / °C
9	Region occupied by panels	0.76 m <sup>2</sup>

Males use commercial resources more frequently, which has improved their quality of life, but my issues have also become apparent [15]. The adverse effects on the environment are arguably the worst. Prior to identifying the specific one, the entire word will be examined [16]. This figure will help in determining how long it will take for current energy sources to completely replace the need for sustainable energy [17], and this solution will be briefly discussed

A. Agra,  $I_R = 957 \text{ W/m}^2$  and  $T_c = 74^\circ \text{C}$

Figure 4: PV Panel Output I-V and P-V Graph

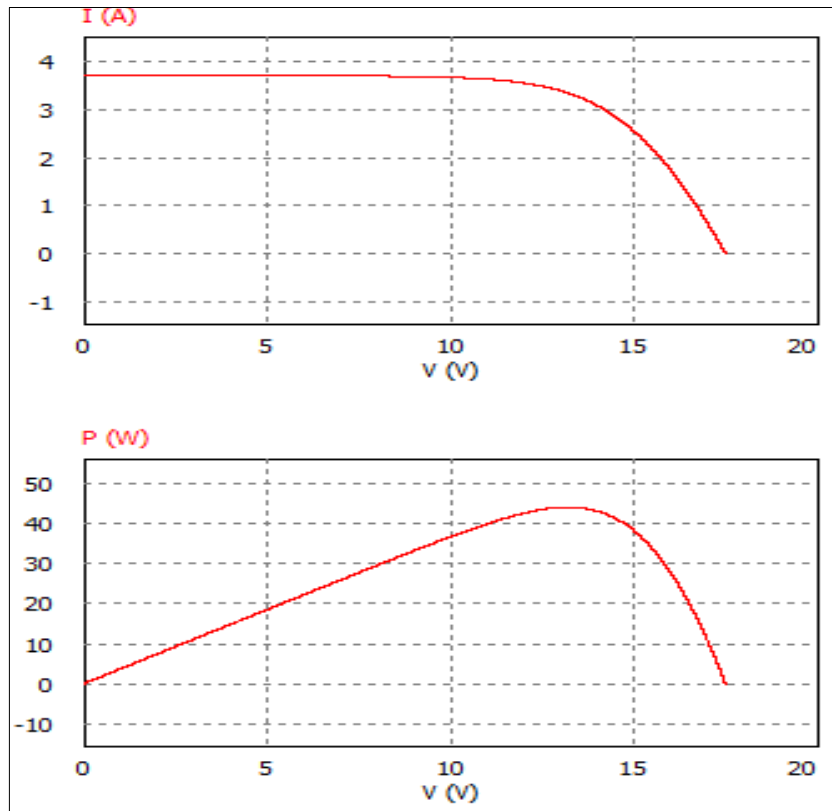

B. Kanpur,  $I_R = 1208 \text{ W/ m}^2$  and  $T_c = 45.722^\circ \text{ C}$

Figure 5: Performance Parameters for the PV Panel

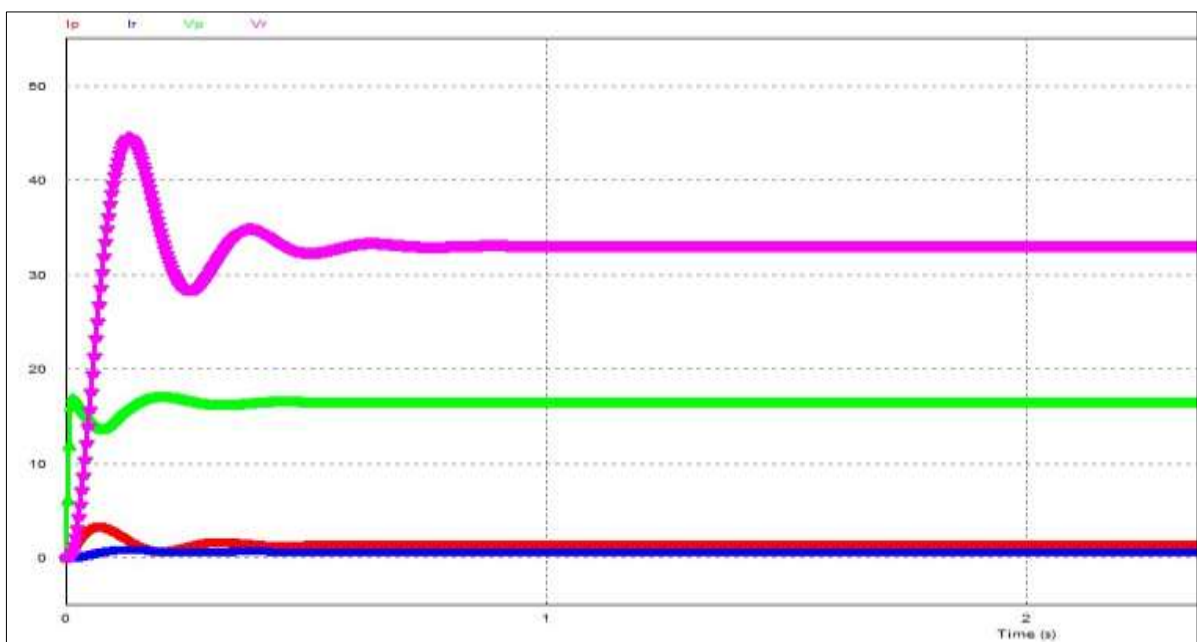

C. Haridwar,  $I_R = 918 \text{ W/m}^2$  and  $T_C = 56.82^\circ \text{ C}$

**Figure 6: PV Panel Output I-V and P-V Graph**

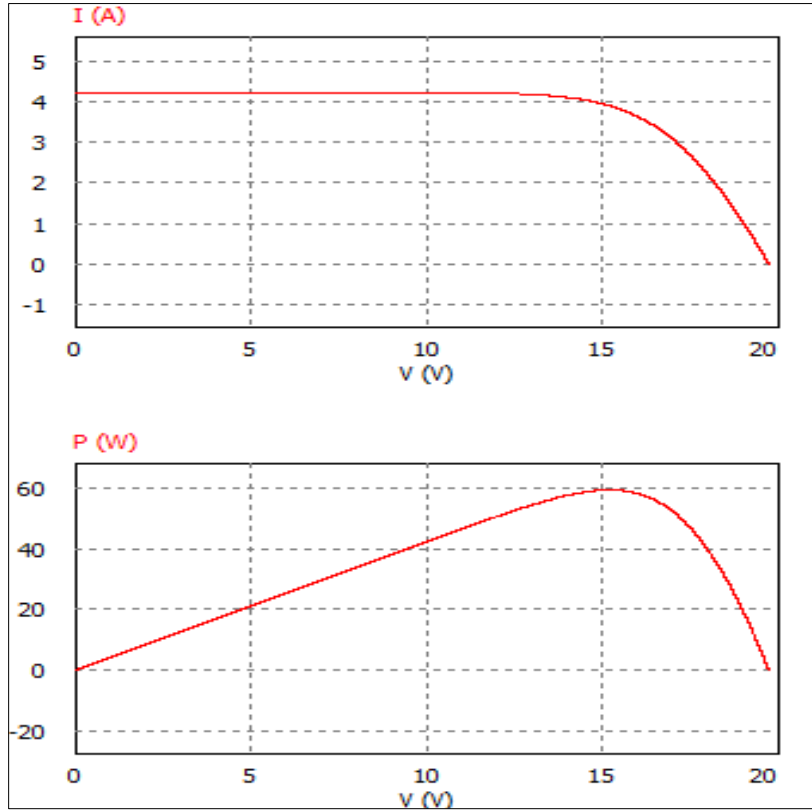

**Table 3: Similarity of PV Panel Performance Characteristics for Various Regions**

Sr. No.	Location	Ppanel	Pload (Boosted)	Vpanel	Vload (Boosted)	Ipanel	Iload (Boosted)
1	Agra	27. W	27.2 W	19.7 V	36.50 V	1.4 A	0.77 A
2	Kanpur	24.1 W	22.8 W	17.5 V	35.02 V	1.4 A	0.76 A
3	Haridwar	25.9 W	25.5 W	18.5 V	36.07 V	1.5 A	0.75 A
4	Initial	34.8 W	32.4 W	20.8 V	38.49 V	1.7 A	0.88 A

The reference conditions, as shown in the above table, are those that are most conducive to the operation of solar panels [19] because they result in the highest conversion efficiency at a sufficient voltage.

**Table 4: Similarity of PV Panel Performance Characteristics for Various Regions**

Sr. No.	Location	$I_r$ ( $\text{W/m}^2$ )	$T_{\text{cell}}$ (C)	Pmax (W)	Vpmax (V)	Ipmax (A)	F. F	$\eta$ (%)
1	Agra	1200	454.6	58.62	16.22	3.82	0.87	10.02%
2	Kanpur	957	72.7	42.25	15.2	3.55	0.99	9.16%
3	Haridwar	926	55.6	45.6	16.48	3.12	0.87	9.62%
4	Initial	1100	27	58.27	17.73	3.64	0.99	11.5%

The above table displays all of the PV Panel's performance metrics after subjecting it to various environmental conditions.

**Table 5: Space Requirements and Location-specific Panel Specifications for Generating 1 KW of Power**

Sr. No.	Region	Single unit	Solar Plates	Size(m <sup>2</sup> ) (Min.)
1	Agra	29.61	29	40
2	Kanpur	24.24	51	41
3	Haridwar	25.87	50	42
4	Initial	34.77	40	45

The table above can be used to deduce a number of things, such as the fact that more panels are required to produce 1000 W as the power produced by a panel decrease, and that as the area required by the panels increases, so does the number of panels required.

#### 4.0 Conclusion

The number of panels required to supply a specific amount of power is inversely related to the power produced by the panels, based on the observations made above. But the quantity of panels required directly correlates with the space they occupy. Therefore, greater irradiation benefits the Ladakh region, but it raises temperature, which is bad for us. Our estimates for various cell temperatures and levels of radiation at various sites also support this fact. High temperatures cause the semiconductor material's band gap to close, releasing an electron from its bond requires less energy, this is the case. As a result, as panel temperature increases, open circuit voltage decreases. Males use commercial resources more frequently, which has improved their quality of life, but my issues have also become apparent. The adverse effects on the environment are arguably the worst. Prior to identifying the specific one, the entire word will be examined [16]. This figure will help in determining how long it will take for current energy sources to completely replace the need for sustainable energy, and this solution will be briefly discussed.

#### References

- [1] C. Marimuthu, "A Study of Factors Affecting Solar PV Cell through Matlab / Simulink Model This study considers the Grid Interactive Roof Top Solar," *IJRSI*, vol. I, no. Iii, pp. 21–25, 2014.
- [2] Demolli, H., Dokuz, A. S., Ecemis, A., & Gokcek, M. (2021). Location-based optimal sizing of hybrid renewable energy systems using deterministic and heuristic algorithms. *International Journal of Energy Research*, 45(11), 16155-16175.
- [3] Demolli, H., Dokuz, A. S., Ecemis, A., & Gokcek, M. (2021). Location-based optimal sizing of hybrid renewable energy systems using deterministic and heuristic algorithms. *International Journal of Energy Research*, 45(11), 16155-16175.
- [4] Usman, Z., Tah, J., Abanda, H., & Nche, C. (2020). A critical appraisal of pv-systems' performance. *Buildings*, 10(11), 192.

- [5] Agrawal, M., Chhajed, P., & Chowdhury, A. (2022). Performance analysis of photovoltaic module with reflector: Optimizing orientation with different tilt scenarios. *Renewable Energy*, 186, 10-25..
- [6] J. Ahmed and Z. Salam, "A Modified P and O Maximum Power Point Tracking Method with Reduced Steady-State Oscillation and Improved Tracking Efficiency," *IEEE Trans. Sustain. Energy*, vol. 7, no. 4, pp. 1506–1515, 2016, doi: 10.1109/TSTE.2016.2568043.
- [7] Perez-Higueras, P. J., Almonacid, F. M., Rodrigo, P. M., & Fernandez, E. F. (2018). Optimum sizing of the inverter for maximizing the energy yield in state-of-the-art high-concentrator photovoltaic systems. *Solar Energy*, 171, 728-739.
- [8] Aghamolaei, R., Shamsi, M. H., & O'Donnell, J. (2020). Feasibility analysis of community-based PV systems for residential districts: A comparison of on-site centralized and distributed PV installations. *Renewable Energy*, 157, 793-808.
- [9] Lupangu, C., & Bansal, R. C. (2017). A review of technical issues on the development of solar photovoltaic systems. *Renewable and Sustainable Energy Reviews*, 73, 950-965.
- [10] Diab, I., Scheurwater, B., Saffirio, A., Chandra-Mouli, G. R., & Bauer, P. (2022). Placement and sizing of solar PV and Wind systems in trolleybus grids. *Journal of Cleaner Production*, 352, 131533.
- [11] Awad, H., Salim, K. E., & Gül, M. (2020). Multi-objective design of grid-tied solar photovoltaics for commercial flat rooftops using particle swarm optimization algorithm. *Journal of Building Engineering*, 28, 101080.
- [12] Mathew, M., Hossain, M. S., Saha, S., Mondal, S., & Haque, M. E. (2022). Sizing approaches for solar photovoltaic-based microgrids: A comprehensive review. *IET Energy Systems Integration*, 4(1), 1-27.
- [13] Sreenath, S., Sudhakar, K., Yusop, A. F., Solomin, E., & Kirpichnikova, I. M. (2020). Solar PV energy system in Malaysian airport: Glare analysis, general design and performance assessment. *Energy Reports*, 6, 698-712.
- [14] Awan, A. B., Zubair, M., & Mouli, K. V. C. (2020). Design, optimization and performance comparison of solar tower and photovoltaic power plants. *Energy*, 199, 117450.
- [15] Khatib, T., & Muhsen, D. H. (2020). Optimal sizing of standalone photovoltaic system using improved performance model and optimization algorithm. *Sustainability*, 12(6), 2233.
- [16] Baqir, M., & Channi, H. K. (2022). Analysis and design of solar PV system using Pvsyst software. *Materials Today: Proceedings*, 48, 1332-1338.
- [17] Chandel, S. S., Naik, M. N., & Chandel, R. (2017). Review of performance studies of direct coupled photovoltaic water pumping systems and case study. *Renewable and Sustainable Energy Reviews*, 76, 163-175.
- [18] Aghaei, M., Kumar, N. M., Eskandari, A., Ahmed, H., de Oliveira, A. K. V., & Chopra, S. S. (2020). Solar PV systems design and monitoring. In *Photovoltaic solar energy conversion* (pp. 117-145). Academic Press..
- [19] J. Siecker, K. Kusakana, and B. P. Numbi, "A review of solar photovoltaic systems cooling technologies," *Renew. Sustain. Energy Rev.*, vol. 79, no. May 2018, pp. 192–203, 2017, doi: 10.1016/j.rser.2017.05.053.