

Article Info

Received: 31 Jan 2019 | Revised Submission: 20 Mar 2019 | Accepted: 28 Apr 2019 | Available Online: 15 Jun 2019

Design and Development of Semi-Automatic Gear Changing Module by Using Pneumatic Drives

Karthik N, Sabari Sriram S.** and Arun Prasad S.****

ABSTRACT

This is the research work regarding the development of pneumatic gear changing module which helps to reduce the gear changing time and increases driver's feasibility on changing gears. The gear changing action is actuated by the pressurized air from the compressor via a pneumatic cylinder to the mechanism. When the driver actuates the push button manually, the gear changing module is actuated by a solenoid valve and the gear is shifted in a shorter time. Additionally, a load device is used to control the speeds of input and output shafts of the gearbox. This method also eliminates the clash due to misplacement of gears, in case of mesh type gearboxes, since; the gears are changed manually by push buttons.

Keywords: *Gearbox; Pneumatic Actuating Mechanism; Semi-Automated.*

1.0 Introduction

Nowadays, automotive industries are assisting automated and semi-automated technologies, instead of existed manually operating elements in their commercial products. As there is an increase in demand in the comfort and safety, hydraulic and pneumatic actuating mechanisms are hired to provide the same. Hydraulic actuators are used where precision and no time lag are needed. Pneumatic elements are cheaper than hydraulics, less compliance, but, similar to hydraulics. Hydraulics finds their applications on steering drives and braking arrangements of the vehicle. Pneumatics is also equipped in suspension systems. An automatic external gear shifting and clutch actuation system for a sequential gearbox has been designed and developed to provide the drivers ease and convenient while shifting gears. Automatically actuated manual transmission system bridges the gap between automatic and manual transmissions which provides the advantages of both types of transmissions [1]. A pneumatic gear changer has been developed by applying the mechatronic principles, in order to reduce gear shifting time with no brake power loss and improved efficiency. The wear and tear of the contact plates are also reduced, by gradual engagement [2].

A conceptual model has been developed to store the brake energy through a hydraulic system in a hydraulic reservoir in heavy-duty vehicles [4]. A gear shifting mechanism was designed and developed for two-wheelers using PLC. This is an approach to implement automatic transmission in bikes [5].

2.0 Development of Pneumatic Gear Shifter

The design approach involved and the components required for the development of the gear changing setup is discussed in this section.

2.1. Components required

The pneumatic semi-automatic gear changer for an automobile comprises of a pneumatic cylinder, an air compressor, a solenoid valve, a push button, a stand, an AC motor, a pulley, and a bearing.

Fig 1(a): Pneumatic Cylinder



*Corresponding Author: Department of Production Engineering, PSG College of Technology, Coimbatore, Tamil Nadu, India (E-mail: karthikmech045@gmail.com)

**Department of Mechanical Engineering, PSG College of Technology, Coimbatore, Tamil Nadu, India

***Department of Mechanical Engineering, PSG College of Technology, Coimbatore, Tamil Nadu, India

Fig 1(b): Air Compressor



Fig 1(f): Spur Gear



Fig 1(c): Solenoid Actuated DCV



Fig 1(g): Bearing



Fig 1(d): AC motor



Fig 1(e): Pulley

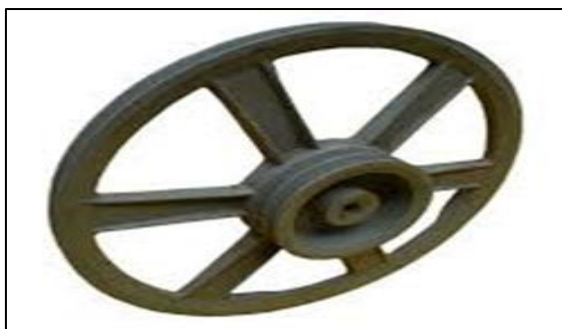

The pneumatic double acting cylinder made of aluminium capable of withstanding up to 10 bar pressure and 45mm diameter and stroke of 100 mm, is used for the actuation of the top and bottom gears through the linear reciprocating action. The air compressor used to pressurize the air up to the required pressure for the functioning of the pneumatic cylinder. The 3/2 directional control valve assisted with solenoids operated at 12 V for the actuation is used for the control of the air flow in the pneumatic system. A single-phase AC motor operating at 230 V, 1440 rpm and 2.5 A, is used to control the rotational motion. Two set of gears for the driver and the driven shaft, representing the gears in an automobile gear assembly. The pulleys and bearings are used to transmit the power and support loads of the components. Few sets of external spur gears of size 80 - 100 mm are used as the transmission elements as traditionally used in the gearboxes.

2.2. Construction

The systematic arrangement is made as shown in figure.2. The double acting cylinder is mounted on the top of the frame.

The double-acting pneumatic cylinder rod is connected to the gear shaft via a gear shifting lever for the engagement of gears. A solenoid switch is connected to the pneumatic cylinder for the actuation of the pneumatic cylinder for gear shifting. The Pulley is mounted on the main shaft to which the AC motor is connected through a belt drive for controlling the gear speed on gear shifting action.

The gear shaft and layshaft are fixed at the bottom and in horizontal to each other. The displacements of the shafts are provided equally to the stroke of the pneumatic cylinder.

A sleeve is mounted in between the two gears and bushes at the other ends of the gears in order to keep the gears in the provided gap. The end of the gear shifting lever is mounted on one of the bushes of the gears. The sleeve and the driver shaft are provided with a splined contact for the linear motion over the shafts. A push button switch is used to control the engagement of gears. The layshaft or the output shaft is fixed. The main shaft or the gear shaft is alone movable through the actuating mechanism.

3.0 Working

When the pushbutton is pressed, the load device controls the speed of the driven shaft to the requirement. After the speed is controlled to the expected value the solenoid valve is actuated and the pneumatic cylinder is extended or retracted. The solenoid valve controls the flow direction of air in order to actuate the gear engagement. On this action, the driver shaft is displaced, and the gear is shifted.

3.1 Shifting from low to high speed

While shifting from low to high speed, the load device increases the speed of the driven shaft gradually and the solenoid makes the pneumatic cylinder extracted and the gear is shifted from low to high.

3.2 Shifting from high to low speed

While shifting from high to low speed, speed is lowered to the speed of the driven shaft and matches with the required speed of the driven shaft for low speed.

1.frame 2.AC motor (load device) 3.Driven shaft pulley 4.Timing belt 5.Gear on driven shaft 6.Bearing 7.pneumatic cylinder (double acting) 8.solenoid switch 9.gear shifting lever 10.switch (pushbutton)

Fig 2: Construction of Pneumatic Gear Changer

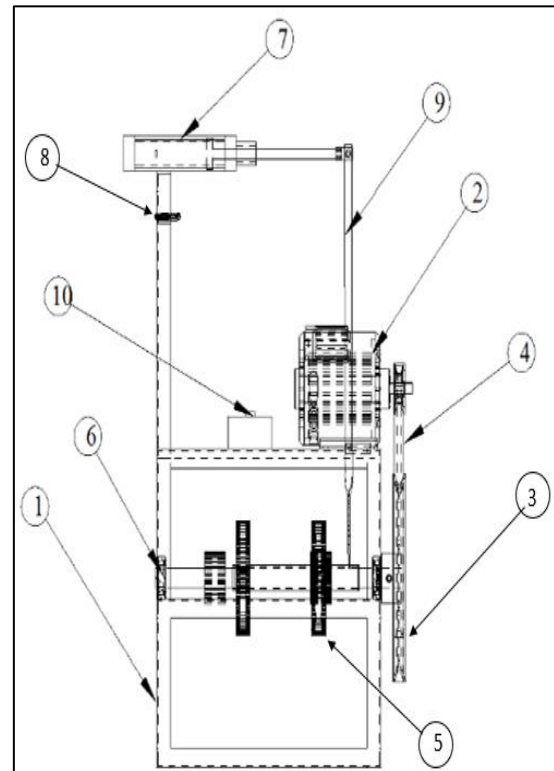
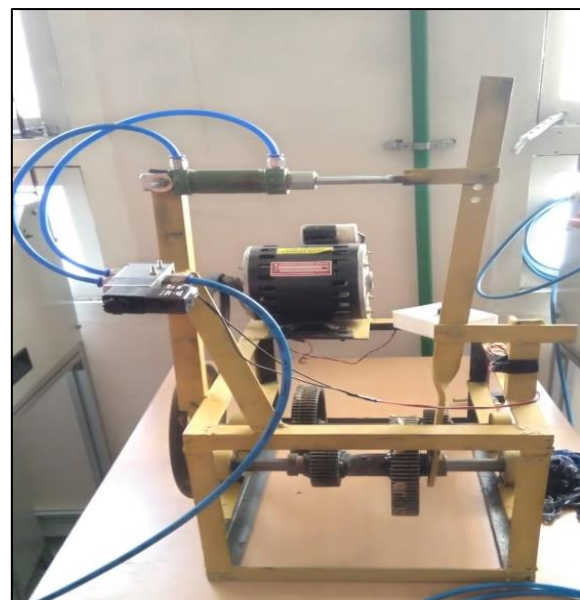

Fig 3: Fabricated Model



3.3 Working of fabricated model

The gear is engaged without any clutch assistance. During the extension action of the pneumatic cylinder, Top gear is engaged as more speed and less torque needed. Similarly, during

retraction, bottom gear is engaged when more torque is needed.

This setup makes the gear changing more convenient to the drivers. The fabricated miniature model is shown in figure 3.

The prototype is checked for its functional capability and found that the gear is shifted in very less time than the traditional gear shifting systems. The response time of the system from the switching of the pushbutton to the engagement of gears lies between 1 to 2 seconds. This value is closer to an ordinary automobile gear shifting time.

4.0 Result and Discussions

This semi-automated gear changing setup is better than others in providing convenience for drivers in case of gears to be shifted since all the actions are sequenced, and automated. The control of the gear engagement is done by the pushbutton closer to the driver, providing better convenience to the driver. As there is no clutch available in this arrangement, no parallel actions are needed while gear shifting. Hence, there is nothing to worry about the maintenance of the clutch and components related to it. The Electric power source and air compressor are required for running the AC motor and supplying required pressurized air for actuating the pneumatic cylinder respectively. This arrangement needs less maintenance and effective in performance.

5.0 Conclusions

This is an economical and efficient gear shifting system, as it eliminates the clutch and reduces maintenance later on. The capital investment

holds greater than a normal clutch and gearbox system in an automobile. But, it is very low then the expenditure on maintenance of an ordinary automobile. The gear shifting time is also lower than the manual clutch-assisted gear shifting mechanism. Considering the comfort of the driver and cost, this is better than the existing gear shifting systems.

References

- [1]. S Dahiya, A Sharma, R Srinivasan, R Tekriwal et al. Electro-Pneumatic Shifting System and Gear Control Unit for a Sequential Gearbox, SAE Technical Paper 2016-28-0175, 2016, 53-55
- [2]. W Wu, X Wang, G Huang, Guan, D Xu. Automatic Gear Sorting System Based on Monocular Vision. Digital Communications and Networks. 104-107, 1.10.1016/j.dcan.2015.10.001.
- [3]. RRS Bravo, D Negri, V Juliano, AAM Oliveira. Design and analysis of a parallel hydraulic – pneumatic regenerative braking system for heavy-duty hybrid vehicles, "Applied Energy, 225(C), 2018, 60-77.
- [4]. T Gandhi, S Bhavsar. Pneumatic gear system, International Journal of Advance Engineering and Research Development, 2017, 11-17.
- [5]. P Vavhal. Improve gear shifting process using devices as auto pneumatic gear shifter, International Research Journal of Engineering and Technology, 3(6), 2016.